

THRU-WALL OR THRU-ROOF CABLE CONNECTORS

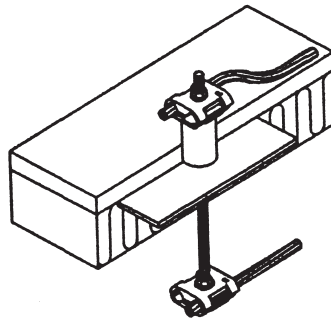

Combination connector for thru-wall or thru-roof penetration giving rigid attachment on both surfaces — assemblies may be used in masonry construction with one end concealed. Neoprene washers are included to provide a moisture seal. Cable clamp No. 55D or No. A55D, lug No. 55B or No. A55B, or tee connector No. 42AN or No. A42AN furnished for either end (any of these connectors fit main sized cables through 9/16" diameter). For copper-to-copper connection, all components are copper or bronze except nuts and washers which are stainless steel — for copper-to-aluminum or aluminum-to-aluminum connection, the threaded rod, nuts and washers are stainless steel. Threaded rod 1/2" diameter, standard length 24" — other lengths available upon request.

- Cat. No. 744CDCD** — Copper Clamp to Copper Clamp - 2 lbs. - 3 oz.
- Cat. No. 744ADCD** — Aluminum Clamp to Copper Clamp - 1lb. - 13 oz.
- Cat. No. 744ADAD** — Aluminum Clamp to Aluminum Clamp - 1lb. - 10 oz.

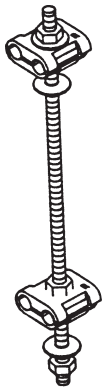

- Cat. No. 744CDCT** — Copper Clamp to Copper Tee Connector - 3 lbs.
- Cat. No. 744ADCT** — Aluminum Clamp to Copper Tee Connector - 3 lbs. - 1 oz.
- Cat. No. 744ADAT** — Aluminum Clamp to Aluminum Tee Connector - 2 lbs. - 11 oz.

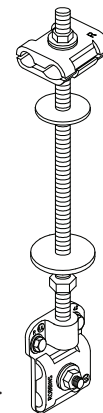
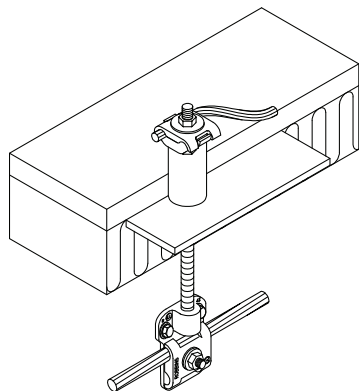

Other combination of parts can be made as needed.

Refer to connectors and letter codes as shown on page 62.



ROBBINS LIGHTNING, INC.

124 EAST SECOND STREET PHONE (660) 582-3156 FAX (660) 582-3039 P.O. BOX 440 MARYVILLE, MISSOURI 64468-0440