

## PIPE CLAMP POINT HOLDER



Heavy cast bronze or aluminum pipe clamp point holder for supporting points on pipe masts, obstruction lights, etc. - 1-1/2" surface contact along axis of pipe. Overall dimensions - 63A-PH 2-1/2" x 1-3/4" - 63B-PH 4-1/4" x 1-1/2" - 63C-PH 5-1/2" x 1-1/2".

### Copper

**Cat. No. 63A-PH** - For 3/4" to 1-1/2" OD pipe - 9 oz.

**Cat. No. 63B-PH** - For 1-3/4" to 2-1/2" OD pipe - 1 lb.

**Cat. No. 63C-PH** - For 2-1/2" to 4-1/2" OD pipe - 1 lb. - 1 oz.

### Aluminum

**Cat. No. A63A-PH** - For 3/4" to 1-1/2" OD pipe - 3.4 oz.

**Cat. No. A63B-PH** - For 1-3/4" to 2-1/2" OD pipe - 6.1 oz.

**Cat. No. A63C-PH** - For 2-1/2" to 4-1/2" OD pipe - 6.6 oz.

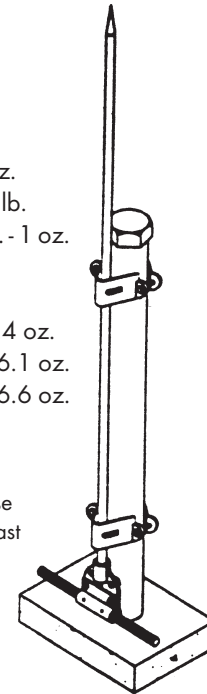
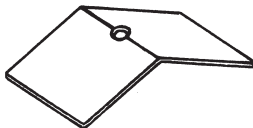
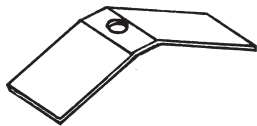
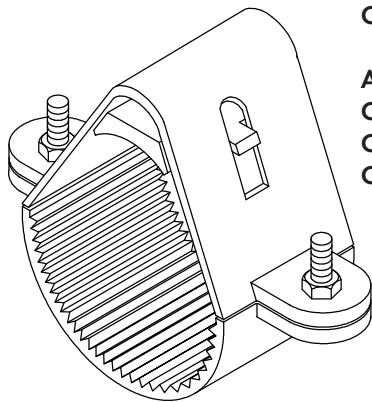

Typical use  
on pipe mast

## CONCEALED POINT FLASHING SADDLE

**Cat. No. 121FS** - Copper - 6.1 oz.

**Cat. No. 121FS-G** - Galvanized - 3.4 oz.

**Cat. No. 121FS-SS** - Stainless - 2.4 oz.

**Cat. No. A121FS** - Aluminum - 1.2 oz.

**NOTE:** Dimensions for flashing saddle must be specified when ordering.

Standard Size is 3" x 10"

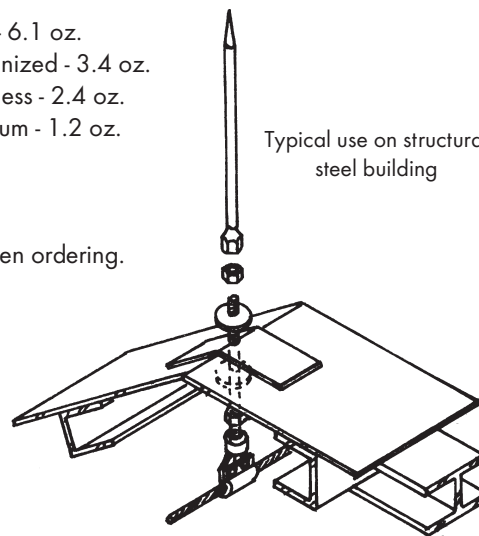

Typical use on structural  
steel building

# ROBBINS LIGHTNING, INC.

124 EAST SECOND STREET PHONE (660) 582-3156 FAX (660) 582-3039 P.O. BOX 440 MARYVILLE, MISSOURI 64468-0440

