

TRIPOD POINT BRACE

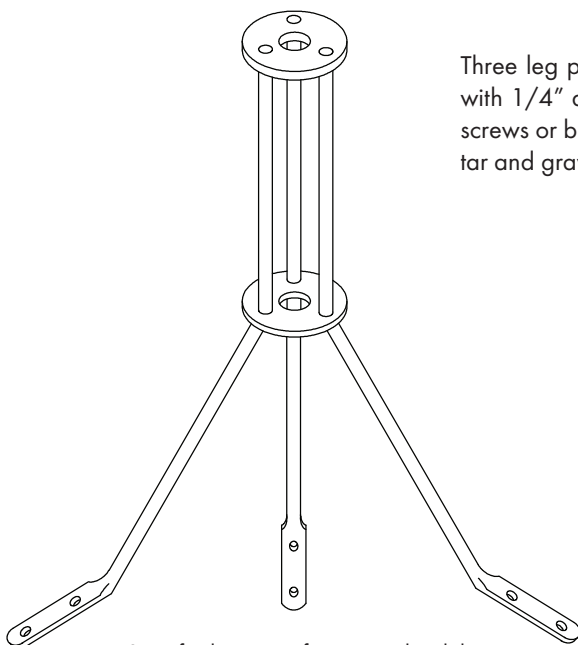

Three leg point brace made of galvanized steel or bare copper with 1/4" diameter legs and heavy washers. For use with nails, screws or bolts. Available with adhesive shoes for use on built-up tar and gravel or membrane roofing.



Specify diameter of point used with brace – 3/8", 1/2" or 5/8".

Typical Application on built-up roof

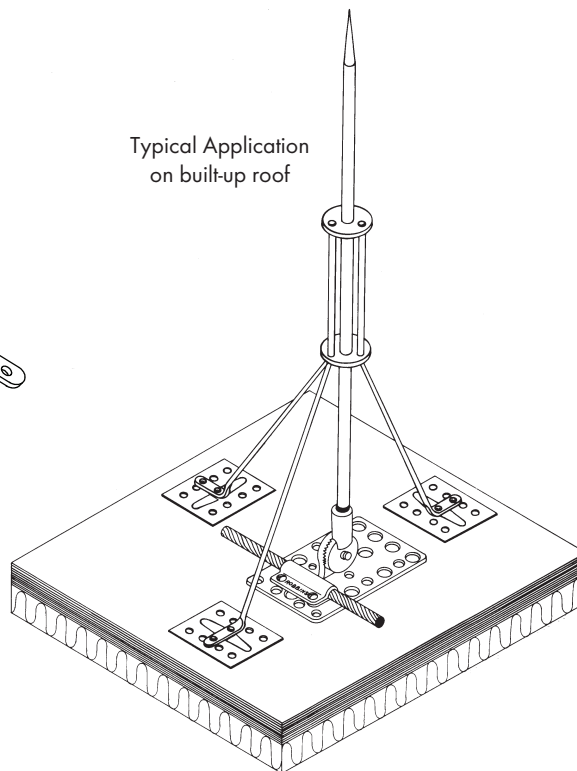

Typical Application on ridge roof

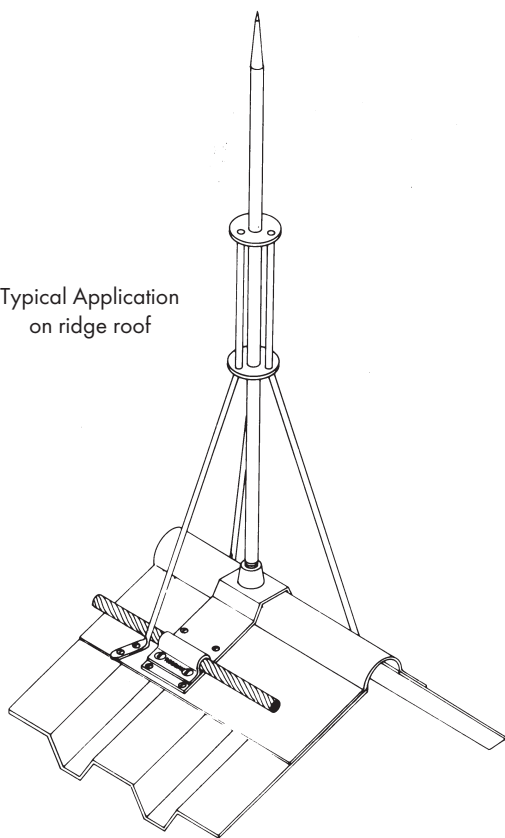

- Cat. No. 43-18G** – Galvanized, 18" long - 11.5 oz.
- Cat. No. 43-18C** – Copper, 18" long - 14.2 oz.
- Cat. No. 43-24G** – Galvanized, 24" long - 1lb. - 2 oz.
- Cat. No. 43-24C** – Copper, 24" long - 1lb. - 3 oz.
- Cat. No. 43-36G** – Galvanized, 36" long - 1lb. - 10 oz.
- Cat. No. 43-36C** – Copper, 36" long - 1lb. - 12 oz.
- Cat. No. 43-42G** – Galvanized, 42" long - 1lb. - 14 oz.
- Cat. No. 43-42C** – Copper, 42" long - 2 lbs.
- Cat. No. 43-48G** – Galvanized, 48" long - 2 lbs.
- Cat. No. 43-48C** – Copper, 48" long - 2 lbs. - 5 oz.

NOTE: Add suffix "A" after above Catalog Numbers when adhesive shoes are needed. Add 1 oz. for copper, 0.3 oz. for galvanized braces.

Longer braces available on request.

ROBBINS LIGHTNING, INC.

124 EAST SECOND STREET PHONE (660) 582-3156 FAX (660) 582-3039 P.O. BOX 440 MARYVILLE, MISSOURI 64468-0440

