

AIRCRAFT TIE-DOWN ANCHOR ROD

Copperclad steel aircraft tie-down anchor rod with copper sleeve compressed on rod – eye radius 1-1/2". These rods meet ASTM-B-371 specifications. While UL 467 does not cover tie-down rods, these rods meet UL's bending test. Rods are manufactured from 3/4" nominal, industry standard ground rods.

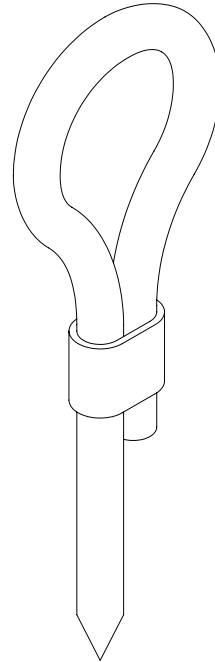

Total Length

Cat. No. 94 - 8TD – 5/8" diameter, 8' Long 7'7" - 7 lbs.

Cat. No. 94 - 10TD – 5/8" diameter, 10' Long 9'7" - 9 lbs.

Cat. No. 97 - 8TD – 3/4" diameter, 8' Long 7'7" - 12 lbs.

Cat. No. 97 - 10TD – 3/4" diameter, 10' Long 9'7" - 15 lbs.

PLASTIC DEPRESSION FORM

Cat. No. 761 - 2.1 oz.

Plastic depression form – snaps over loop on tie-down anchor rod to form depression approximately 6" long by 4" wide by 3" deep around standard 5/8" or 3/4" diameter anchor rod.

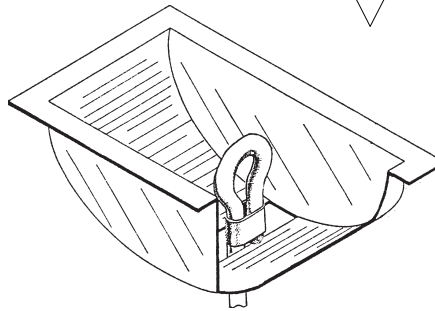

Typical application of form on tie-down rod

COPPERCLAD ANCHOR

A copperclad helix anchor, for use with aircraft tie-down rods.

Cat. No. 95B - for 3/4" rods - 2 lbs. - 15 oz.

When ordering 95A or 95B with aircraft tie-down order tie-down with threads.

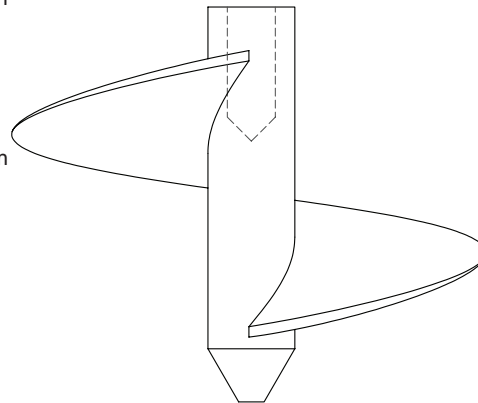

ROBBINS LIGHTNING, INC.

124 EAST SECOND STREET PHONE (660) 582-3156 FAX (660) 582-3039 P.O. BOX 440 MARYVILLE, MISSOURI 64468-0440

