

## BUS BAR ACCESSORIES

### STAND-OFF INSULATORS

Insulator of reinforced polyester for use in mounting bus bar away from wall to allow clamping or bolting of lugs and terminals to bar – 3/8" threaded inserts – maximum stand-off 4" recommended.

**Cat. No. 619** – 1-1/2" high, 1-3/4" diameter

**Cat. No. 619A** – 2" high, 1-3/4" diameter

Other sizes available upon request.

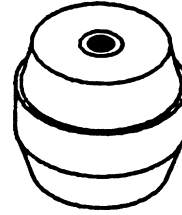

### STAND-OFF BRACKETS

Bracket made of 1/8" thick by 1" wide stainless steel stock for mounting bus bar away from wall to allow clamping or bolting of lugs and terminals to bar – 3/8" holes for mounting with screws or masonry anchors. Stand-off distance 1-1/2" – ears 1" wide. May be used alone or with insulator.

**Cat. No. 469**

**Cat. No. 469-4**

Same as above except 4" across top, for mounting 4" wide bus bar.

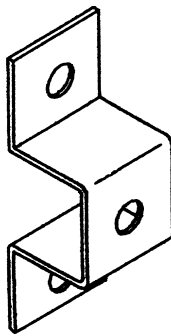

Other sizes available on special order.

NOTE: Special ground bars can be fabricated from standard bus bar stock (see page 11) with any combination of holes drilled or drilled and tapped.

# ROBBINS LIGHTNING, INC.

124 EAST SECOND STREET PHONE (660) 582-3156 FAX (660) 582-3039 P.O. BOX 440 MARYVILLE, MISSOURI 64468-0440

-117-

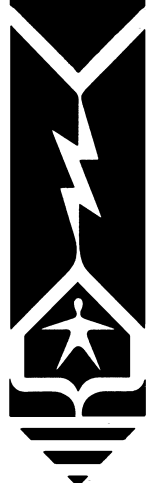

## BUS BAR ACCESSORIES

### GROUNDING STUD

Machined brass stud for use in static ground receptacle or as grounding point on copper bus bar – standard 1/2" knob for spring clip or battery type clip – threaded 5/16" NC – furnished plain as shown (No. 880) or with 5/16" nut and lockwasher (No. 880A).

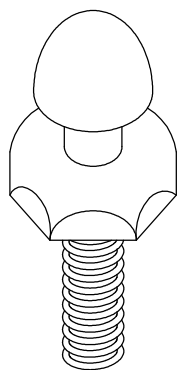

1/2 actual size

Typical use on bus bar

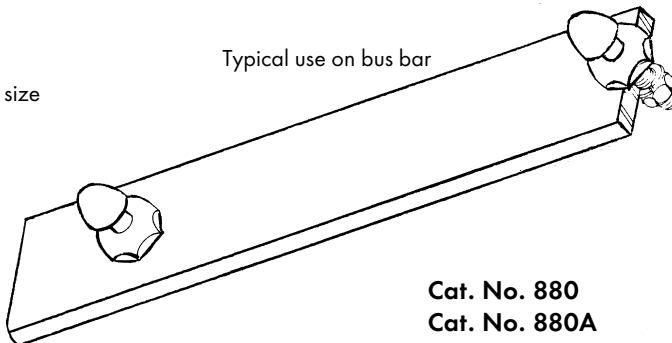

**Cat. No. 880**  
**Cat. No. 880A**

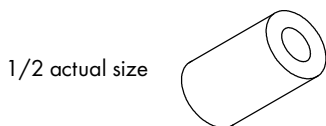

1/2 actual size

### FIBER SPACER

Bus bar spacer of impact resistant, non-conductive fiber – for use in holding bar away from wall to allow clamping or bolting of lugs and terminals to bar – 3/8" ID and 3/4" OD – for use on bus bar to 1-1/2" wide – maximum stand-off 2" recommended.

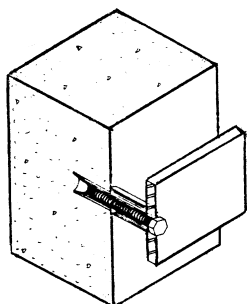

Typical use as  
bus bar spacer

**Cat. No. 617** – 1/2" long  
**Cat. No. 617A** – 3/4" long  
**Cat. No. 617B** – 1" long  
**Cat. No. 617C** – 1-1/2" long  
**Cat. No. 617D** – 2" long

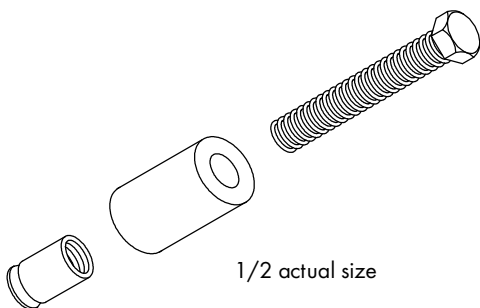

1/2 actual size

### ANCHOR SPACER ASSEMBLY

Assembly for mounting bus bar consists of No. 617 series fiber spacer, No. 86 lead anchor and proper length of 1/4" diameter screw.

**Cat. No. 618** – 1/2" spacer, 1-1/4" screw  
**Cat. No. 618A** – 3/4" spacer, 1-1/2" screw  
**Cat. No. 618B** – 1" spacer, 1-3/4" screw  
**Cat. No. 618C** – 1-1/2" spacer, 2-1/4" screw  
**Cat. No. 618D** – 2" spacer, 2-3/4" screw



# ROBBINS LIGHTNING, INC.

124 EAST SECOND STREET PHONE (660) 582-3156 FAX (660) 582-3039 P.O. BOX 440 MARYVILLE, MISSOURI 64468-0440