

ALUMINUM POINTS — STANDARD

ALL ITEMS



Aluminum points made from solid rod, drawn to a sharp point, threaded to fit bases. Specify thread size when ordering. Shipped with 1/2" threads for use on Class I systems, or 5/8" threads for use on Class II systems.



Standard sizes available from stock:

- Cat. No. A25** – 1/2" diameter x 10" long
- Cat. No. A24** – 1/2" diameter x 12" long
- Cat. No. A23** – 1/2" diameter x 15" long
- Cat. No. A22** – 1/2" diameter x 18" long
- Cat. No. A21A** – 1/2" diameter x 24" long
- Cat. No. A20A** – 1/2" diameter x 30" long
- Cat. No. A19A** – 1/2" diameter x 36" long
- Cat. No. A19A48** – 1/2" diameter x 48" long
- Cat. No. A19A60** – 1/2" diameter x 60" long

- Cat. No. A25B** – 5/8" diameter x 10" long
- Cat. No. A24B** – 5/8" diameter x 12" long
- Cat. No. A23B** – 5/8" diameter x 15" long
- Cat. No. A22B** – 5/8" diameter x 18" long
- Cat. No. A21C** – 5/8" diameter x 24" long
- Cat. No. A20C** – 5/8" diameter x 30" long
- Cat. No. A19C** – 5/8" diameter x 36" long
- Cat. No. A19C48** – 5/8" diameter x 48" long
- Cat. No. A19C60** – 5/8" diameter x 60" long

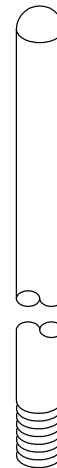

Points also available with blunt tips. (Add -BT to part numbers shown.)

SPECIAL POINT INFORMATION

The above listed points are carried in stock for immediate shipment — other points of special lengths and diameters are available, including 3/4" and 1" diameters.

Lengths over 144" are made by coupling an extension rod to points listed above. Extension rods available in 1/2", 5/8", 3/4" and 1" diameters and lengths up to 144".

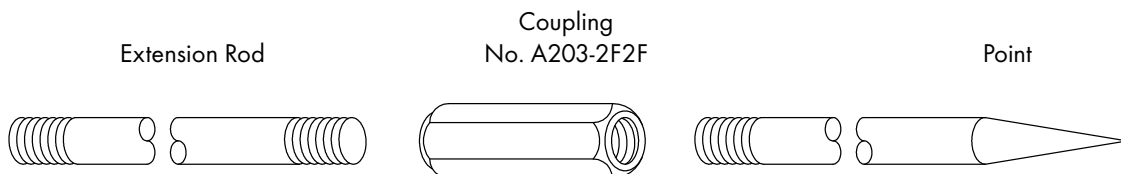

NOTE: Spring Point Assemblies also available — see page 48.

ROBBINS LIGHTNING, INC.

124 EAST SECOND STREET PHONE (660) 582-3156 FAX (660) 582-3039 P.O. BOX 440 MARYVILLE, MISSOURI 64468-0440



COPPER POINTS — STANDARD

ALL ITEMS



Bare copper points made from solid rod, drawn to a sharp point, and threaded to fit bases. Standard threads on 5/8" diameter points are 1/2", 5/8" threads available on special order. Also available in nickel plated copper — add -NP to catalog number when ordering.

Standard sizes available from stock:



- | | |
|-----------------------|----------------------------|
| Cat. No. 25A | – 3/8" diameter x 10" long |
| Cat. No. 24A | – 3/8" diameter x 12" long |
| Cat. No. 23A | – 3/8" diameter x 15" long |
| Cat. No. 22A | – 3/8" diameter x 18" long |
| Cat. No. 21B | – 3/8" diameter x 24" long |
| Cat. No. 20B | – 3/8" diameter x 30" long |
| Cat. No. 19B | – 3/8" diameter x 36" long |
| Cat. No. 19B48 | – 3/8" diameter x 48" long |
| Cat. No. 19B60 | – 3/8" diameter x 60" long |
| Cat. No. 25 | – 1/2" diameter x 10" long |
| Cat. No. 24 | – 1/2" diameter x 12" long |
| Cat. No. 23 | – 1/2" diameter x 15" long |
| Cat. No. 22 | – 1/2" diameter x 18" long |
| Cat. No. 21A | – 1/2" diameter x 24" long |
| Cat. No. 20A | – 1/2" diameter x 30" long |
| Cat. No. 19A | – 1/2" diameter x 36" long |
| Cat. No. 19A48 | – 1/2" diameter x 48" long |
| Cat. No. 19A60 | – 1/2" diameter x 60" long |
| Cat. No. 25B | – 5/8" diameter x 10" long |
| Cat. No. 24B | – 5/8" diameter x 12" long |
| Cat. No. 23B | – 5/8" diameter x 15" long |
| Cat. No. 22B | – 5/8" diameter x 18" long |
| Cat. No. 21C | – 5/8" diameter x 24" long |
| Cat. No. 20C | – 5/8" diameter x 30" long |
| Cat. No. 19C | – 5/8" diameter x 36" long |
| Cat. No. 19C48 | – 5/8" diameter x 48" long |
| Cat. No. 19C60 | – 5/8" diameter x 60" long |



Points also available with blunt tips. (Add -BT to part numbers shown.)

SPECIAL POINT INFORMATION

The above listed points are carried in stock for immediate shipment — other points of special lengths and diameters are available, including 3/4" and 1" diameters.

Lengths over 144" are made by coupling an extension rod to points listed above. Extension rods available in 1/2", 5/8", 3/4" and 1" diameters and lengths up to 144".

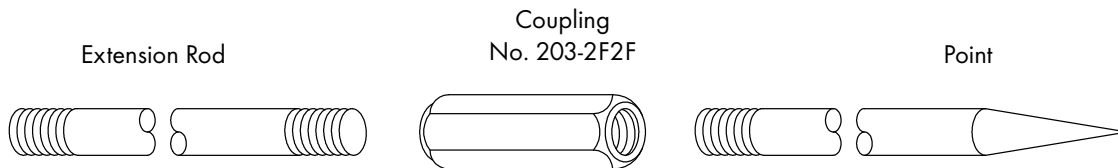

NOTE: Spring Point Assemblies also available — see page 48.

ROBBINS LIGHTNING, INC.

124 EAST SECOND STREET PHONE (660) 582-3156 FAX (660) 582-3039 P.O. BOX 440 MARYVILLE, MISSOURI 64468-0440

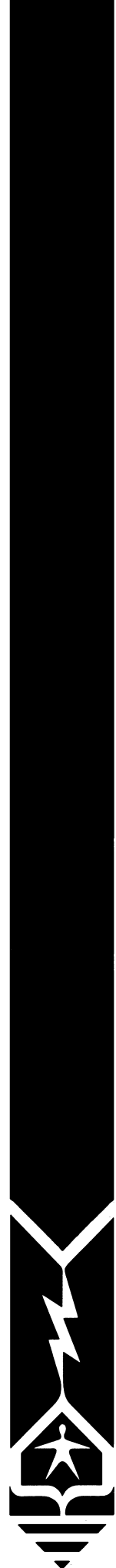

CHIMNEY AIR TERMINALS

ALL ITEMS



With No. 42 Copper or
No. A42L Aluminum

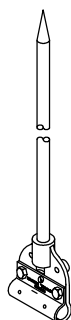

With No. 42A Copper
or No. A42A Aluminum

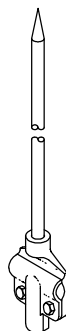

With No. 42B Copper
or No. A42B Aluminum

Points also available
with blunt tips.
(Add -BT to part
numbers shown.)

Chimney air terminals consist of a bare, solid copper or aluminum point with heavy cast bronze or aluminum base, which come in three types – straight, tee or combination.

Note: Codes require copper points used on chimneys to be lead covered to protect against corrosion for a distance of 2 feet below top of chimney. For chimneys with flue size over 24", lead jacket required 1/16" thick. For chimney's with flue size 24" or less, lead-dipped point may be used.

Copper – Lead Dipped

Cat. No. 38A-42 – 1/2" diam. x 4' long with No. 42 Base

Cat. No. 38A-42A – 1/2" diam. x 4' long with No. 42A Base

Cat. No. 38A-42B – 1/2" diam. x 4' long with No. 42B Base

Cat. No. 39A-42 – 1/2" diam. x 3' long with No. 42 Base

Cat. No. 39A-42A – 1/2" diam. x 3' long with No. 42A Base

Cat. No. 39A-42B – 1/2" diam. x 3' long with No. 42B Base

Cat. No. 38B-42 – 3/8" diam. x 4' long with No. 42 Base

Cat. No. 38B-42A – 3/8" diam. x 4' long with No. 42A Base

Cat. No. 38B-42B – 3/8" diam. x 4' long with No. 42B Base

Cat. No. 39B-42 – 3/8" diam. x 3' long with No. 42 Base

Cat. No. 39B-42A – 3/8" diam. x 3' long with No. 42A Base

Cat. No. 39B-42B – 3/8" diam. x 3' long with No. 42B Base

Copper – Lead Jacket

Cat. No. 38-42 – 1/2" diam. x 4' long with No. 42 Base

Cat. No. 38-42A – 1/2" diam. x 4' long with No. 42A Base

Cat. No. 38-42B – 1/2" diam. x 4' long with No. 42B Base

Cat. No. 39-42 – 1/2" diam. x 3' long with No. 42 Base

Cat. No. 39-42A – 1/2" diam. x 3' long with No. 42A Base

Cat. No. 39-42B – 1/2" diam. x 3' long with No. 42B Base

Cat. No. 38C-42 – 3/8" diam. x 4' long with No. 42 Base

Cat. No. 38C-42A – 3/8" diam. x 4' long with No. 42A Base

Cat. No. 38C-42B – 3/8" diam. x 4' long with No. 42B Base

Cat. No. 39C-42 – 3/8" diam. x 3' long with No. 42 Base

Cat. No. 39C-42A – 3/8" diam. x 3' long with No. 42A Base

Cat. No. 39C-42B – 3/8" diam. x 3' long with No. 42B Base

Aluminum

Cat. No. A38A-A42L – 1/2" diam. x 4' long with No. A42L Base

Cat. No. A38A-A42A – 1/2" diam. x 4' long with No. A42A Base

Cat. No. A38A-A42B – 1/2" diam. x 4' long with No. A42B Base

Cat. No. A39A-A42L – 1/2" diam. x 3' long with No. A42L Base

Cat. No. A39A-A42A – 1/2" diam. x 3' long with No. A42A Base

Cat. No. A39A-A42B – 1/2" diam. x 3' long with No. A42B Base

ROBBINS LIGHTNING, INC.

124 EAST SECOND STREET PHONE (660) 582-3156 FAX (660) 582-3039 P.O. BOX 440 MARYVILLE, MISSOURI 64468-0440



STANDARD CONCEALED POINTS

ALL ITEMS



Concealed Point Assembly of bare copper or aluminum. Consists of 10" point length with balance threaded for roof insert. Nuts and washers draw tight to prevent leak. Base No. 42A for horizontal direction of cable run. Available in nickel plated copper on request (Add -NP to copper part numbers shown).

Copper

- Cat. No. 34-18 – 1/2" diameter x 18" long
- Cat. No. 34-24 – 1/2" diameter x 24" long
- Cat. No. 34-30 – 1/2" diameter x 30" long

- Cat. No. 34A-18 – 3/8" diameter x 18" long
- Cat. No. 34A-24 – 3/8" diameter x 24" long
- Cat. No. 34A-30 – 3/8" diameter x 30" long

- Cat. No. 34B-18 – 5/8" diameter x 18" long
- Cat. No. 34B-24 – 5/8" diameter x 24" long
- Cat. No. 34B-30 – 5/8" diameter x 30" long

Aluminum

- Cat. No. A34-18 – 1/2" diameter x 18" long
- Cat. No. A34-24 – 1/2" diameter x 24" long
- Cat. No. A34-30 – 1/2" diameter x 30" long

- Cat. No. A34B-18 – 5/8" diameter x 18" long
- Cat. No. A34B-24 – 5/8" diameter x 24" long
- Cat. No. A34B-30 – 5/8" diameter x 30" long

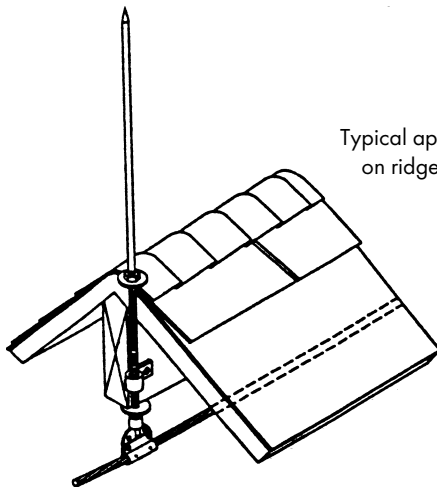

Typical application
on ridged roof

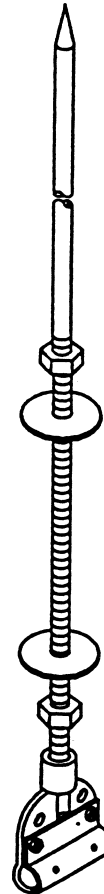

Points also available
with blunt tips.
(Add -BT to part
numbers shown.)

ROBBINS LIGHTNING, INC.

124 EAST SECOND STREET PHONE (660) 582-3156 FAX (660) 582-3039 P.O. BOX 440 MARYVILLE, MISSOURI 64468-0440

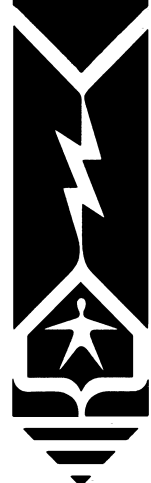

SPECIAL POINTS

ALL ITEMS
MARKED *



TAPERED GOVERNMENT POINT

Cast bronze or aluminum point with full length taper – 1/2" male thread to fit all point bases – available in bronze finish (No. 26), nickel plated bronze (No. 26A) or aluminum (No. A26) – length from hub – 16".

*Cat. No. 26 – Copper

*Cat. No. 26A – Copper

*Cat. No. A26 – Aluminum

TUBULAR POINT WITH DOWEL ADAPTER

Tubular copper or aluminum point with dowel adapter securely clamped to lower end with male thread for all point bases – 5/8" outside diameter with 0.049" thick wall – copper points bright nickel tipped.

Copper

*Cat. No. 27 – 12" long

*Cat. No. 27A – 15" long

*Cat. No. 27B – 18" long

*Cat. No. 27C – 24" long

Aluminum

*Cat. No. A27 – 12" long

*Cat. No. A27A – 15" long

*Cat. No. A27B – 18" long

*Cat. No. A27C – 24" long



1/4 actual size

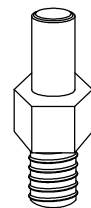

1/4 actual size

DOWEL ADAPTER

Brass or aluminum dowel adapter for use with tubular points – 1/2" male thread.

Cat. No. 720 – Copper

Cat. No. A720 – Aluminum

1/2 actual size

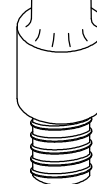

ROBBINS LIGHTNING, INC.

124 EAST SECOND STREET PHONE (660) 582-3156 FAX (660) 582-3039 P.O. BOX 440 MARYVILLE, MISSOURI 64468-0440

SPECIAL PURPOSE POINTS

BAYONET TYPE POINT

Bayonet type point of cast bronze or aluminum. Low profile total length 11". Furnished with 1/2" male end for all point bases. Available in Bronze finish (#31), Chrome Plated Bronze (#31A), or Satin Aluminum (#A31).

Cat. No. 31 – Copper

Cat. No. 31A – Chromed Copper

Cat. No. A31 – Aluminum

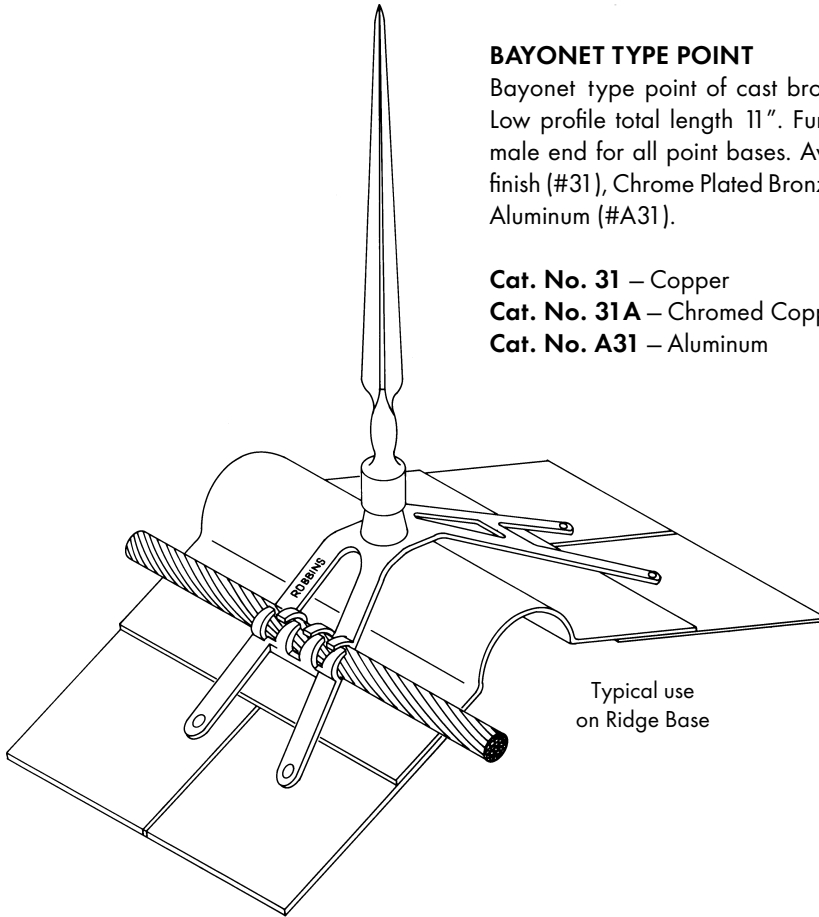

Typical use
on Ridge Base

1/2 Actual Size



TUBULAR VENT POINT

Tubular Vent Point of copper or aluminum. Provides 3 square inch contact surface and 10 inch point length. Fasten to metal surface with metal screws or bolts and nuts.

Cat. No. 37 – Copper

Cat. No. A37 – Aluminum



1/4 Actual Size

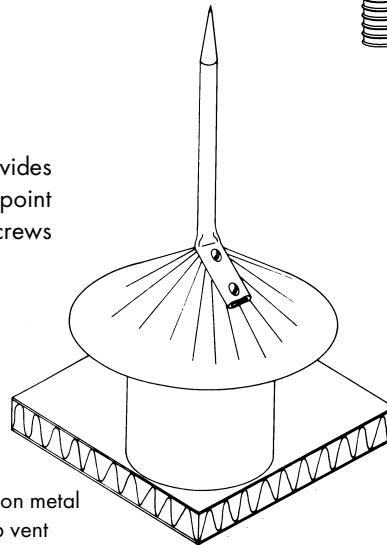

Typical use on metal
cone top vent

ROBBINS LIGHTNING, INC.

124 EAST SECOND STREET PHONE (660) 582-3156 FAX (660) 582-3039 P.O. BOX 440 MARYVILLE, MISSOURI 64468-0440

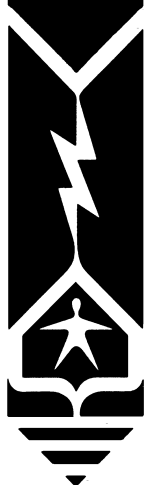

ALL THREAD ROD AND POINT EXTENSION ROD



ALL THREAD ROD

All thread rod with standard N.C. threads.
Available in lengths up to 144".

Copper

Cat. No. 220 – 3/8" – 16 threads

Cat. No. 221 – 1/2" – 13 threads

Cat. No. 222 – 5/8" – 11 threads

Aluminum

Cat. No. A221 – 1/2" – 13 threads

Cat. No. A222 – 5/8" – 11 threads

Stainless Steel

Cat. No. 220SS – 3/8" – 16 threads

Cat. No. 221SS – 1/2" – 13 threads



POINT EXTENSION ROD

Solid copper or aluminum rod for extending length of points – standard N.C. thread both ends – available in lengths to 144". May also be substituted for stranded cable to prevent mechanical damage or to bridge open spaces.

Specify exact length required,
such as Cat. No. 212 (1/2" x 48").

Copper

Cat. No. 212 – 1/2" diameter

Cat. No. 213 – 3/8" diameter

Cat. No. 214 – 5/8" diameter

Aluminum

Cat. No. A212 – 1/2" diameter

Cat. No. A214 – 5/8" diameter

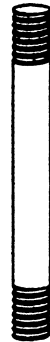

SAFETY BALLS



Machined brass or aluminum safety tip, 1-1/2" diameter, with internal threads - to be used on copper or aluminum extension rods in place of standard sharp points where safety to workers or pedestrians is a concern.

Cat. No. 110F – Copper

Cat. No. A110F – Aluminum

Cat. No. 110 – Copper

Cat. No. A110 – Aluminum

Specify diameter of threads – 3/8", 1/2" or 5/8".

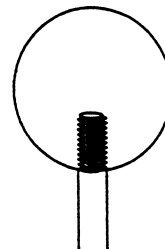

Typical use on
midroof point

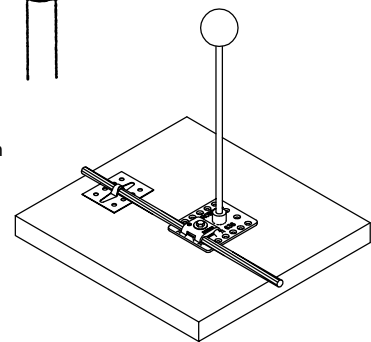
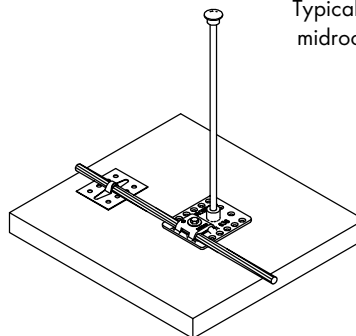
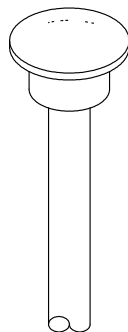

ROBBINS LIGHTNING, INC.

124 EAST SECOND STREET PHONE (660) 582-3156 FAX (660) 582-3039 P.O. BOX 440 MARYVILLE, MISSOURI 64468-0440



COUPLINGS AND ADAPTERS FOR POINTS



ROD COUPLINGS

Couplings made of brass or aluminum hex rod for extending point lengths and adapting points to various special purpose bases. Overall length 1-1/2".

Copper

- Cat. No. 203-2F2F – 1/2" Female to 1/2" Female
- Cat. No. 203-3F3F – 3/8" Female to 3/8" Female
- Cat. No. 203-2F3F – 1/2" Female to 3/8" Female
- Cat. No. 203-5F5F – 5/8" Female to 5/8" Female
- Cat. No. 203-2F5F – 1/2" Female to 5/8" Female

- Cat. No. 203-2F2M – 1/2" Female to 1/2" Male
- Cat. No. 203-3F3M – 3/8" Female to 3/8" Male
- Cat. No. 203-2F3M – 1/2" Female to 3/8" Male
- Cat. No. 203-3F2M – 3/8" Female to 1/2" Male
- Cat. No. 203-5F5M – 5/8" Female to 5/8" Male
- Cat. No. 203-2F5M – 1/2" Female to 5/8" Male
- Cat. No. 203-5F2M – 5/8" Female to 1/2" Male

- Cat. No. 203-2M2M – 1/2" Male to 1/2" Male
- Cat. No. 203-3M3M – 3/8" Male to 3/8" Male
- Cat. No. 203-2M3M – 1/2" Male to 3/8" Male
- Cat. No. 203-5M5M – 5/8" Male to 5/8" Male
- Cat. No. 203-2M5M – 1/2" Male to 5/8" Male

Aluminum

- Cat. No. A203-2F2F – 1/2" Female to 1/2" Female
- Cat. No. A203-5F5F – 5/8" Female to 5/8" Female
- Cat. No. A203-2F5F – 1/2" Female to 5/8" Female

- Cat. No. A203-2F2M – 1/2" Female to 1/2" Male
- Cat. No. A203-5F5M – 5/8" Female to 5/8" Male
- Cat. No. A203-2F5M – 1/2" Female to 5/8" Male
- Cat. No. A203-5F2M – 5/8" Female to 1/2" Male

- Cat. No. A203-2M2M – 1/2" Male to 1/2" Male
- Cat. No. A203-5M5M – 5/8" Male to 5/8" Male
- Cat. No. A203-2M5M – 1/2" Male to 5/8" Male



Male to Male



Female to Male



Female to Female

BASE CENTER SET

Machined brass or aluminum fittings for use on all strap type point bases or for adapting points to metal surface up to 1/8" thick. Nut drilled and tapped with 3/8", 1/2" or 5/8" NC thread – bolt has 1/2" or 5/8" NC thread.

NOTE: When ordering aluminum base center set, No. A143L stainless steel lockwasher should also be ordered for tightening.

Copper

- Cat. No. 803-2 – 1/2" nut
- Cat. No. 803-3 – 3/8" nut
- Cat. No. 803-5 – 5/8" nut

- Cat. No. 804-2 – 1/2" bolt
- Cat. No. 804-5 – 5/8" bolt

Aluminum

- Cat. No. A803-2 – 1/2" nut
- Cat. No. A803-5 – 5/8" nut

- Cat. No. A804-2 – 1/2" bolt
- Cat. No. A804-5 – 5/8" bolt

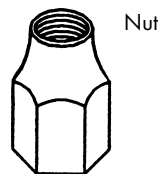

Nut

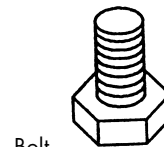

Bolt

ROBBINS LIGHTNING, INC.

124 EAST SECOND STREET PHONE (660) 582-3156 FAX (660) 582-3039 P.O. BOX 440 MARYVILLE, MISSOURI 64468-0440

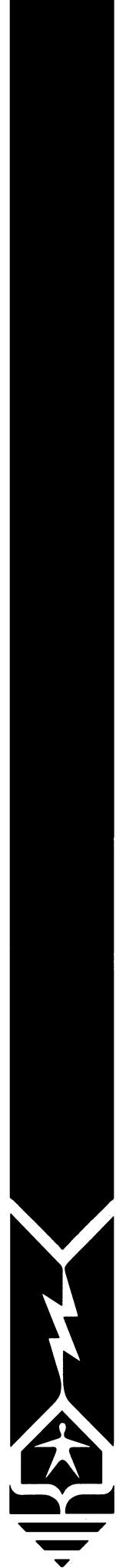

DOUBLE SWIVEL ADAPTERS



Double swivel adapters for use with standard points and bases to alter direction of point – each end threaded or drilled and tapped for desired use.

Female to Female

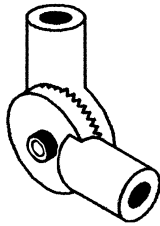

Female to Male

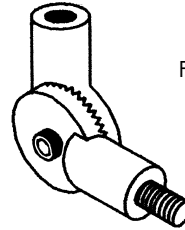

HEAVY CAST SWIVEL

Copper

- Cat. No. 836-2F2F – 1/2" Female to 1/2" Female
- Cat. No. 836-2F2M – 1/2" Female to 1/2" Male
- Cat. No. 836-2F3F – 1/2" Female to 3/8" Female
- Cat. No. 836-2M3F – 1/2" Male to 3/8" Female
- Cat. No. 836-3F3F – 3/8" Female to 3/8" Female
- Cat. No. 836-3F3M – 3/8" Female to 3/8" Male

Aluminum

- Cat. No. A836-2F2F – 1/2" Female to 1/2" Female
- Cat. No. A836-2F2M – 1/2" Female to 1/2" Male

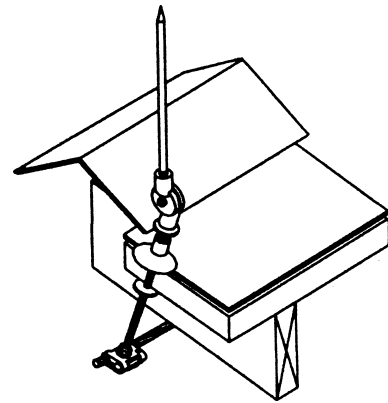

Typical use on sloping surface point

MACHINED SWIVEL MADE OF HEX BRASS OR ALUMINUM

Copper

- Cat. No. 837-2F2F – 1/2" Female to 1/2" Female
- Cat. No. 837-2F2M – 1/2" Female to 1/2" Male
- Cat. No. 837-2F3F – 1/2" Female to 3/8" Female
- Cat. No. 837-2M3F – 1/2" Male to 3/8" Female
- Cat. No. 837-3F3F – 3/8" Female to 3/8" Female
- Cat. No. 837-3F3M – 3/8" Female to 3/8" Male
- Cat. No. 837-2F5F – 1/2" Female to 5/8" Female
- Cat. No. 837-2M5F – 1/2" Male to 5/8" Female
- Cat. No. 837-5F5F – 5/8" Female to 5/8" Female
- Cat. No. 837-5F5M – 5/8" Female to 5/8" Male

Aluminum

- Cat. No. A837-2F2F – 1/2" Female to 1/2" Female
- Cat. No. A837-2F2M – 1/2" Female to 1/2" Male
- Cat. No. A837-2F5F – 1/2" Female to 5/8" Male
- Cat. No. A837-2M5F – 1/2" Male to 5/8" Female
- Cat. No. A837-5F5F – 5/8" Female to 5/8" Female
- Cat. No. A837-5F5M – 5/8" Female to 5/8" Male

Female to Female

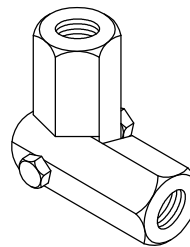

Female to Male

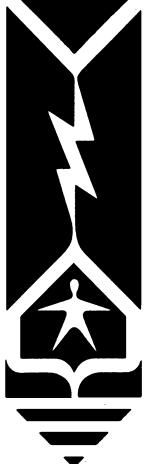
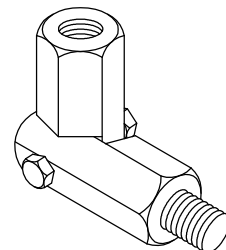

ROBBINS LIGHTNING, INC.

124 EAST SECOND STREET PHONE (660) 582-3156 FAX (660) 582-3039 P.O. BOX 440 MARYVILLE, MISSOURI 64468-0440